

Cypress Lighting Technologies

1123 McKaskle Drive, Hammond, Louisiana

985-318-7112



Street Corn Lamp

LED Turtle Friendly Corn 15W

Model: CL-15W-XX(CL/FR)-T AC100-277V 600nm-605nm Amber Color

Product Features:

- ◇ IP64 rated, dustproof, insect proof, **Clear** or **Frosted** Cover
- ◇ No Fan design, internal driver, aluminum driver box, heat-conducting glue covered driver
- ◇ With IC temperature control inside, also no strob flash
- ◇ Can be used in fully sealed fixture
- ◇ Certificate: UL, cUL, CE, RoHS
- ◇ 50000 hours lifespan, 3 years warranty



Technical Specifications

Model	CL-15W-XX(CL/FR)-T
Rate Power	15W±5%
Input Voltage	AC100-277V 50/60Hz
Light Color	Amber Color
Wavelength	600nm-605nm
Power Factor	>0.9
Lumens	220lm±5%
Lighting Source	LED 2835SMD
Operating Temp.	-20~45°C
Mounting	E26 E27
Rated Life	Up to 50,000 Hrs.
LED LM80	Yes

Dimensions

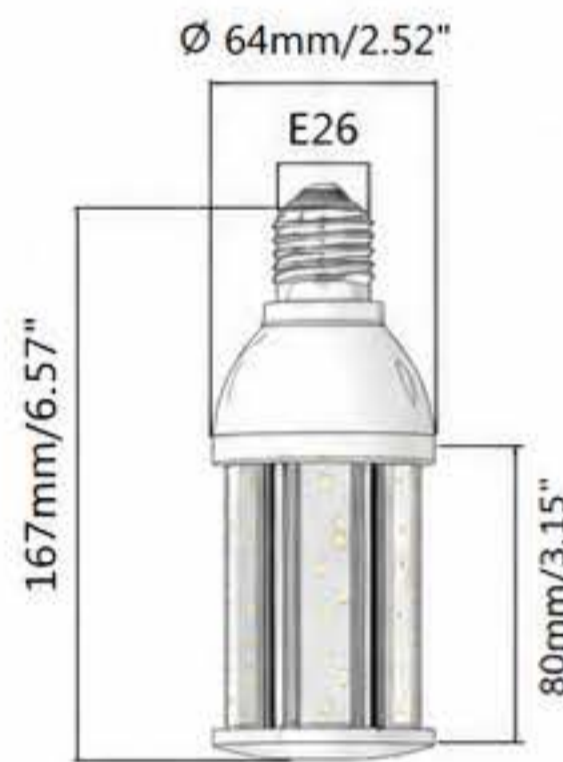

Applications



Installations



Street Lighting / Acorn

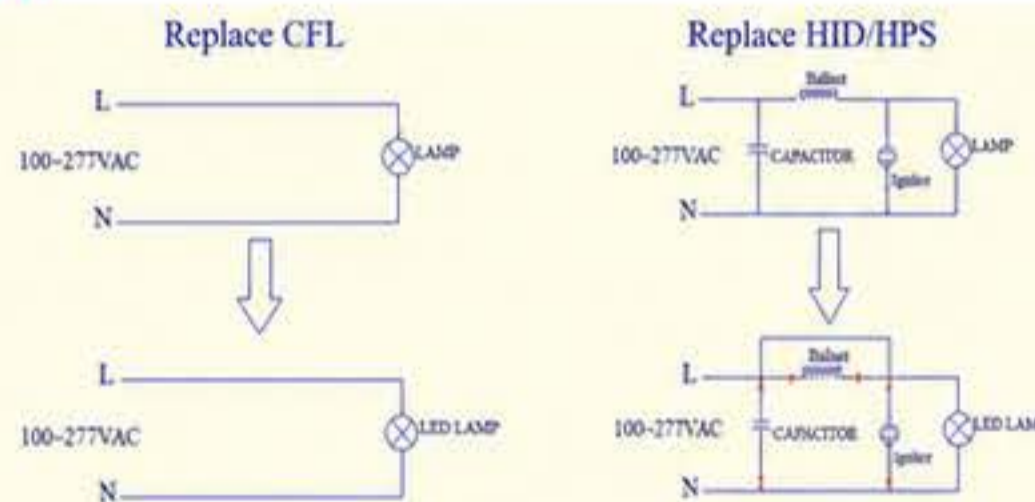

Wildlife Lighting Certification

Number: 2018-022



Packing Details

Pack Quantity	25PCS/Carton
Net Weight Per CTN	0.75lbs/340g
Gross Weight Per CTN	24.69lbs/11.2kg
Inner Box Size	2.95" x 2.95" x 7.68"
Master Carton Size	15.9" x 15.9" x 9"

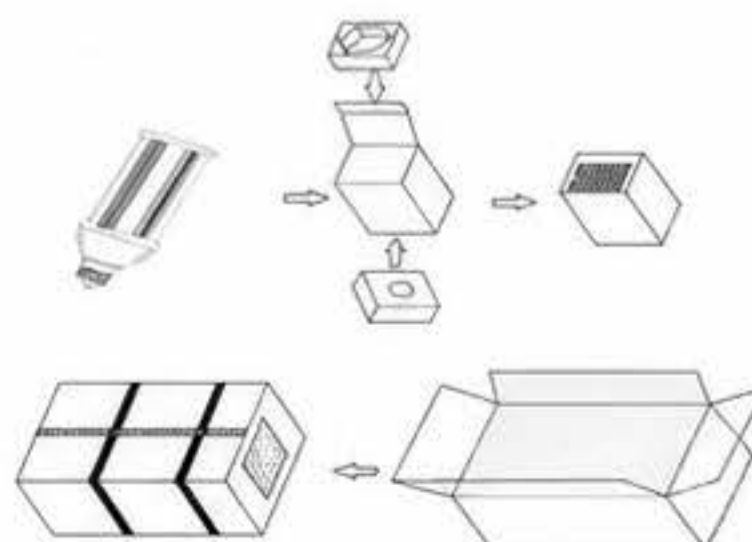

<p>Omnidirectional</p> <p>360° Illumination</p>	<p>Suitable</p> <p>For Enclosed Luminaires</p>	<p>Solid State</p> <p>Vibration and Shock Resistant</p>	<p>Reliability</p> <p>LM-80 Tested ISTMT Tested</p>
<p>Lumen Efficacy</p> <p>140 lpw LM-79 Tested</p>	<p>Warranty</p> <p>3 years</p> <p>Safe and Reliable</p>	<p>Sustainability</p> <p>Environmentally Friendly</p>	